

Panasonic

Operating Instructions

Forms Printer

Model No. **KX-P3200**



Please read these instructions completely before operating this unit. Store this manual with care.

Congratulations on purchasing a Panasonic printer

This printer is a versatile, high quality 9-pin dot matrix printer which is designed to meet the needs of your office. This printer has been factory set to operate with the most popular software packages. Your application software should control the printer functions. In most cases, there will be no need to change the factory settings.

The serial number of the unit may be found on the label on the rear of the unit. For your convenience, note this number below, and retain this book, along with your proof of purchase, to serve as a permanent record of your purchase in the event of a theft, or for future reference.

MODEL NO **KX-P3200** _____

NAME OF DEALER _____

SERIAL NO _____

DATE OF PURCHASE _____

Warning.

- The power source voltage of this unit is listed on the nameplate. Plug the printer's 3-prong cord into an outlet with the proper voltage.
- To prevent fire or shock hazard, do not expose this product to rain or any type of moisture.

Caution.

- When you operate this equipment, the outlet should be near the equipment and should be easily accessible.
- To prevent parallel/serial interface and printhead from static electricity damage, before you touch them, discharge any static electricity from your hands by touching a grounded metal surface. (However, do not touch the printhead when it is hot.)

FOR YOUR SAFETY

To ensure safe operation the three-pin plug supplied must be inserted only into a standard three-pin power point which is effectively earthed through the normal household wiring.

Extension cords used with the equipment must be three-core and be correctly wired to provide connection to earth. Improperly wired extension cords are a major cause of fatalities.

The fact that the equipment operates satisfactorily does not imply that the power point is earthed and that the installation is completely safe. For your safety, if in any doubt about the effective earthing of the power point, consult a qualified electrician.

If the plug cannot be inserted into the AC outlet, contact a licensed electrician to replace the outlet with properly grounded one. Do not defeat the purpose of the grounding plug (ex. do not use a conversion plug).

IBM, IBM-PC and Proprinter are trademarks of International Business Machines Corporation.

Microsoft® and Windows® are registered trademarks of Microsoft Corporation in the United States and/or other countries.

Epson is a trademark of Seiko Epson Corporation.

Printer Driver Program for Windows 3.1

All Rights Reserved © COPYRIGHT 1990 – 1992 Microsoft Corporation

Printer Driver Program for Windows 95

All Rights Reserved © COPYRIGHT 1991 – 1995 Microsoft Corporation

Any details given in these Operating Instructions are subject to change without notice.

All Rights Reserved © COPYRIGHT 1996 KYUSHU MATSUSHITA ELECTRIC CO., LTD

Unpacking

Having unpacked the printer, make sure none of the contents shown below are missing or damaged. Report damages or shortages to the store from which the unit was purchased.

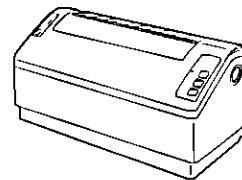

Printer

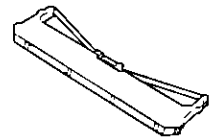

Ribbon cassette (KX-P180)



Platen knob



Power cord

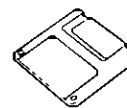

Setup Disk



Operating Manual
Quick Start Guide

- The Setup Disk contains a Printer Driver for Windows 3.1 and Windows 95 (see P 11), a Control Panel Software program (see P 13) and a Command Reference program (see P 15).
- To use this Setup Disk, you need to have an IBM-PC or a compatible computer with 3.5" floppy disk drive.

Note

- It is recommended that you save the original carton and packing materials for proper shipping and transporting of the printer.

Table of Contents

2 Warning/Caution

2 Unpacking

Chap 1 Read Me First

4 End-User License Agreement

5 Cautions

5 Operating Environment

5 Precautions

6 Parts of the Printer

Chap 2 Setup

7 Connecting to a Computer

7 Power Supply

8 Installing Ribbon Cassette

9 Handling Paper

9 Installing Paper

10 Tearing off Paper

10 Self Test

10 Printer Driver Selection

Chap 3 Installing and Using the Setup Disk

11 Installing the Setup Disk

11 For DOS

11 For Windows 3.1

12 For Windows 95

13 Using the Setup Disk

13 Control Panel Software Program

15 Command Reference Program

Chap. 4 Using the Control Panel

16 Using the Control Panel and DIP Switch

16 Selecting a Character Font

16 Line Feed/Form Feed (LF/FF)

16 Paper Loading (LOAD)

17 Top of Form Function (TOF SET)

17 Paper Out Detector

18 Initial Setup Mode

19 Returning All Current Settings to the Factory Settings

19 Using the DIP Switch

Chap. 5 Periodic Maintenance/Troubleshooting

20 Periodic Maintenance

20 Troubleshooting

21 Options and Supplies

Appendix

24 Printer Specifications

25 Paper Specifications

25 Printing Area

26 Interfacing

26 Parallel Interfacing

26 Serial Interfacing

27 Index

The Setup Disk contains the following programs and informations
Please refer to this manual how to use

- Printer Driver for Windows 3.1 (P 11)
- Printer Driver for Windows 95 (P 12)
- Control Panel Software Program (P 13)
- Command Reference Program (P 15)
- Character Set Tables (P 15)
- Proportional Spacing Tables (P 15)

Chap. 1

Chap. 2

Chap. 3

Chap. 4

Chap. 5

Appendix

End-User License Agreement

THIS IS A LEGAL AGREEMENT BETWEEN YOU AND PANASONIC CAREFULLY READ ALL THE TERMS AND CONDITIONS OF THIS AGREEMENT PRIOR TO OPENING THE PACKET OF SOFTWARE PROGRAM OPENING THE PACKET INDICATES YOUR ACCEPTANCE OF THESE TERMS AND CONDITIONS If you do not agree to these terms and conditions, return the unopened packet and the other components of the Panasonic product to the place of purchase and your money will be refunded No refunds will be given for the products that have an opened packet or missing components

1. COPYRIGHT:

Panasonic has the right to license or has been granted to license the enclosed Software Program ("SOFTWARE"), developed and copyrighted by Kyushu Matsushita Electric Co., Ltd. or its licensor ("Licensor") You acknowledge that you are receiving only a LIMITED LICENSE TO USE the SOFTWARE and related documentation, and that you shall obtain no title, ownership nor any other rights in or to the SOFTWARE and related documentation, all of which title and rights shall remain with Licensor and Panasonic

2 LICENSE:

(1) You have the non-exclusive right to use the one copy of the SOFTWARE on a single computer used by single user Installation of the SOFTWARE on a network server for the purpose of distribution to one or more other computers shall not be granted in this Agreement (2) You may not copy, reproduce, or permit to be copied or reproduced, the SOFTWARE or related documentation for any purpose, except that you may either (a) make a reasonable quantity of copies of the SOFTWARE solely for backup or archival purposes, or (b) transfer the SOFTWARE to a single hard disk, provided that you keep the original solely for backup or archival purposes (3) You may not rent or lease the SOFTWARE, but you may transfer your right under this License Agreement on a permanent basis, provided that you transfer this Agreement, all copies of the SOFTWARE, all related documentation and your Panasonic product, and the recipient thereof agrees to the terms of this Agreement (4) You may not reverse engineer, decompile or disassemble the SOFTWARE, except that in European Union and European Free Trade Association, you may have the limited right to reverse engineer, decompile or disassemble the SOFTWARE solely to the extent specifically permitted by the terms and conditions of Article 6 of the European Community's Directive for the Legal Protection of Computer Programs, OJL 122/42 (17 May 1991) (5) You may not use, copy, modify, alter, or transfer the SOFTWARE, or any copy thereof, in whole or in part, except as expressly provided in this Agreement

3. TERM

This license is effective until terminated You may terminate this Agreement at any time by destroying the SOFTWARE and related documentation and all copies thereof This license will also terminate if you fail to comply with any term or condition of this Agreement Upon such termination, you agree to destroy all copies of the SOFTWARE and related documentation

4. LIMITED WARRANTY.

Within ninety (90) days of your receipt of the SOFTWARE, Panasonic warrants that the storage media on which the SOFTWARE are furnished is free from defect in materials and workmanship under normal use, and that it will repair or at its option replace any defective media at no charge to you, provided that such defective media is returned to Panasonic within such ninety (90) days period

5 LIMITATION OF LIABILITY.

EXCEPT AS STATED ABOVE, NEITHER PANASONIC NOR PANASONIC'S SUPPLIER MAKES OR PASSES ON TO YOU OR OTHER THIRD PARTY, ANY WARRANTY OR REPRESENTATION INCLUDING, BUT NOT LIMITED TO, THE IMPLIED WARRANTY OF MERCHANTABILITY AND FITNESS FOR A PARTICULAR PURPOSE WITHOUT LIMITING THE GENERALITY OF THE FOREGOING, NEITHER PANASONIC NOR PANASONIC'S SUPPLIER WARRANTS THAT THE SOFTWARE WILL BE ERROR-FREE OR THAT IT WILL MEET YOUR REQUIREMENTS NEITHER PANASONIC NOR PANASONIC'S SUPPLIER SHALL BE LIABLE FOR ANY DAMAGE SUFFERED BY YOU INCLUDING, BUT NOT LIMITED TO, CONSEQUENTIAL, INCIDENTAL SPECIAL OR PUNITIVE DAMAGES THE ABOVE LIMITATIONS SHALL APPLY REGARDLESS OF THE FORM OF ACTION WHETHER IN CONTRACT, TORT (INCLUDING NEGLIGENCE), STRICT PRODUCT LIABILITY OR OTHERWISE, EVEN IF SUCH PARTY HAS BEEN ADVISED OF THE POSSIBILITY OF SUCH DAMAGES

Cautions

Operating Environment

Do not use the printer under the following conditions to avoid machine malfunction

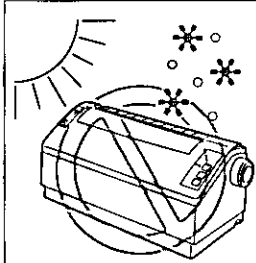

- Extremely high or low temperature [temperature range 10~35°C (50~95°F)]

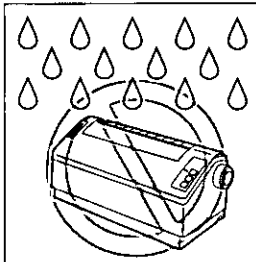

- Extremely high or low humidity (humidity range 20~80% RH)

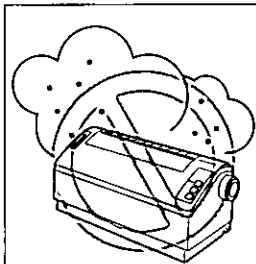

- Areas of high dust concentration

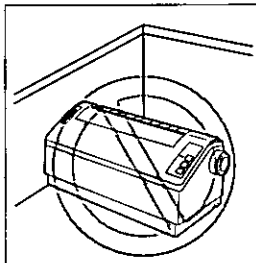

- Areas of poor ventilation [a minimum of 4" (10 cm) clearance on all sides is necessary to insure proper ventilation]

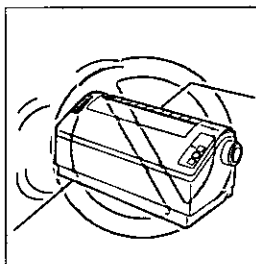

- Areas with extreme vibration or when placed on an unstable, unlevel or leaned surface

Precautions

The following precautions are recommended to extend the life of the printer

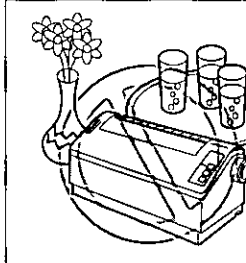

- Keep all liquids away from the printer
 - Accidental spillage of a liquid into the printer can cause severe damage

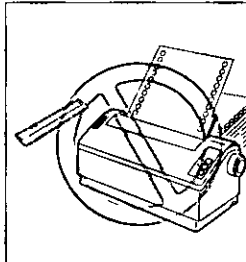

- Do not operate the printer without paper and a ribbon cassette installed

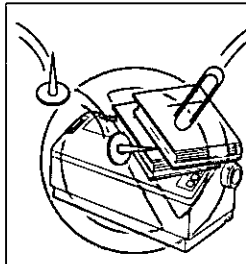

- Do not place books, paper, or other items on top of the printer
- Do not obstruct the movement of the printhead while in operation

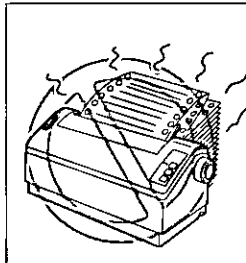

- Avoid prolonged use without allowing the printhead time to cool

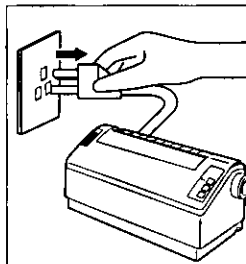

- If the printer is not going to be used for an extended period, unplug the power cord

Parts of the Printer

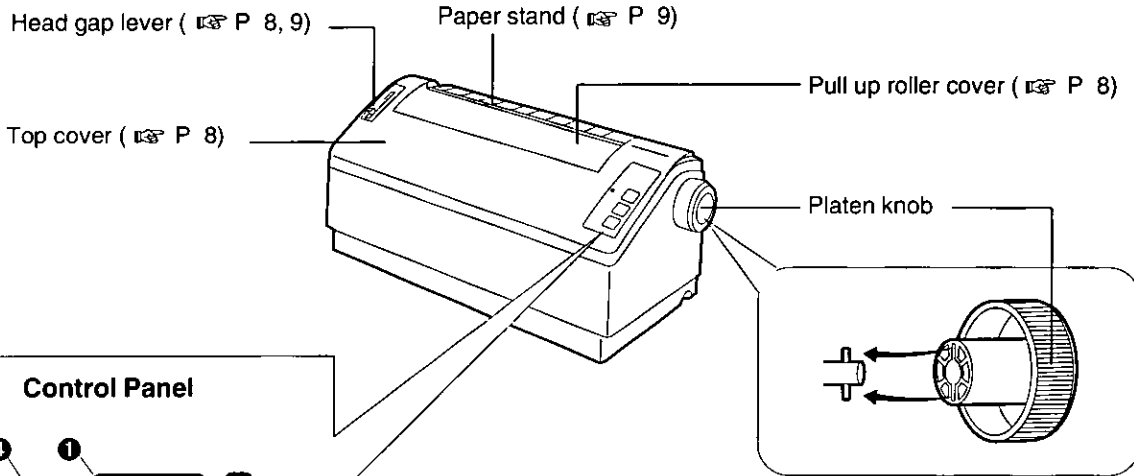

Control Panel

1 FONT Switch (P 16)

2 READY Switch

3 LF/FF Switch (P 16)
LOAD Switch (P 16)

4 FONT indicators (P 16)

5 READY indicator

6 POWER/PAPER OUT indicator (P 17)

7 Micro Line Feed/TOF SET (P 17)

POWER
PAPER OUT

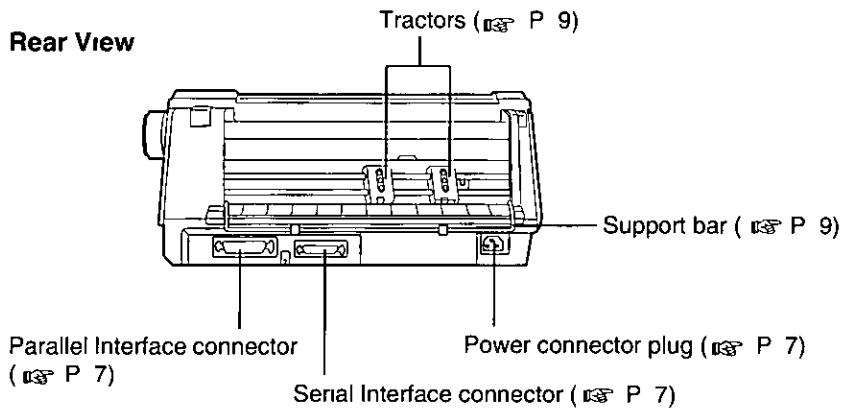
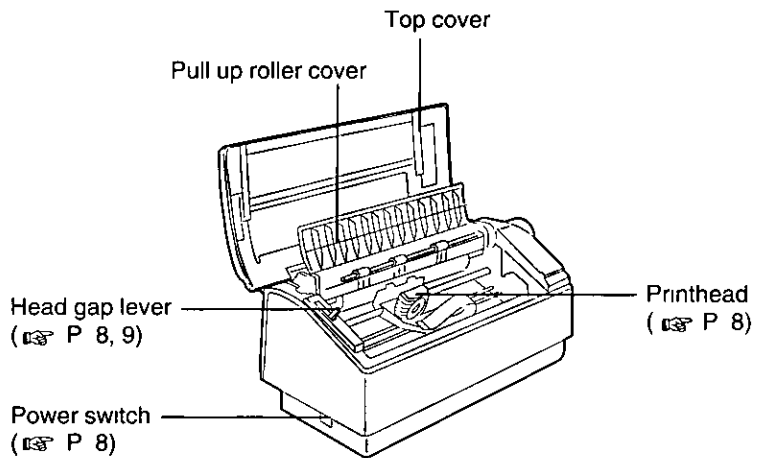

Connecting to a Computer

- 1 Turn the power off and unplug the power cord.
- 2 Attach other end of the interface cable from your computer.

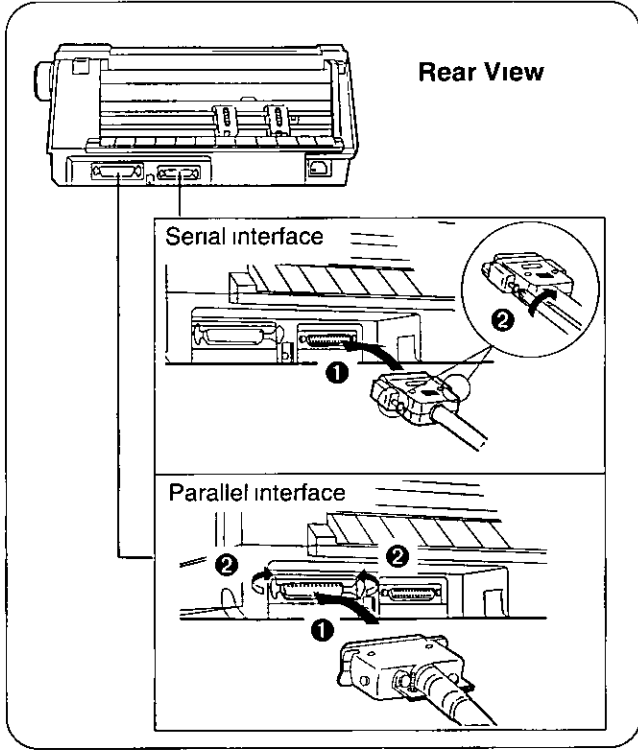

Note.

- Take care not to drop the printer when you slant the printer to connect the cable
- Use a shielded cable 6'5" (1.95 m) or less in length for both of parallel and serial
If you do not already have an interface cable, you will need to purchase one from your local computer store or dealer. For details, refer to "Interfacing" (P 26)
- If the cable has a frame ground wire, connect it to the frame ground terminal

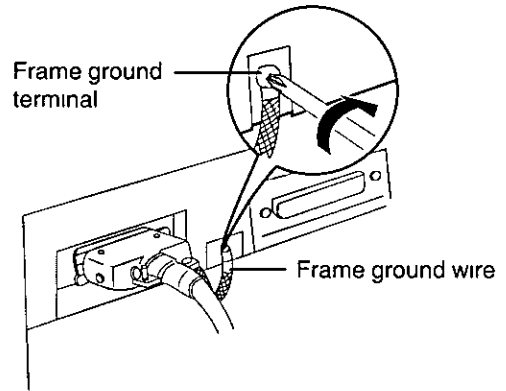

Power Supply

- 1 Connect the power cord firmly into the printer's power connector plug.
- 2 Plug the power cord into a grounded 3-prong AC socket.

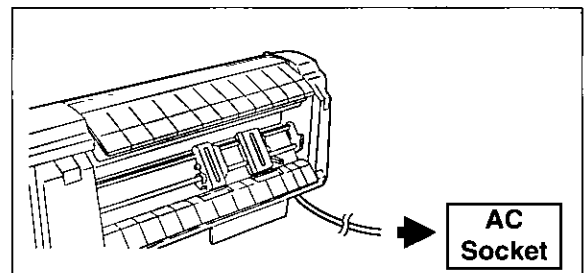
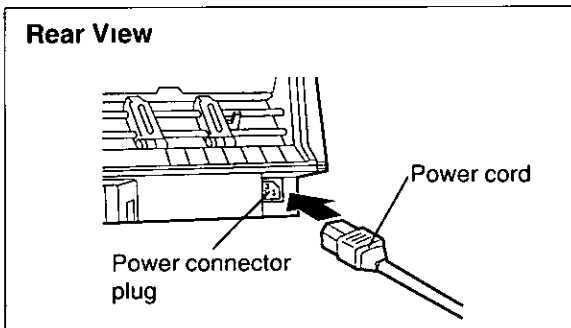

Note:

- Take care not to drop the printer when you slant the printer to connect the power cord
- If the power cord is not connected firmly, there is a fear of becoming hot

Installing Ribbon Cassette

- 1**
- ① Turn the power on.
 - ② Shift the head gap lever to position "6".

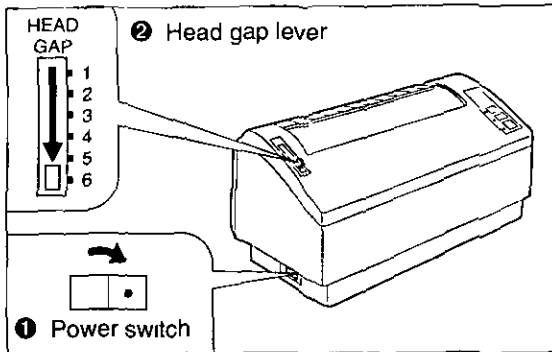

- 2**
- ① Raise the top cover.
 - ② Raise the pull up roller cover.

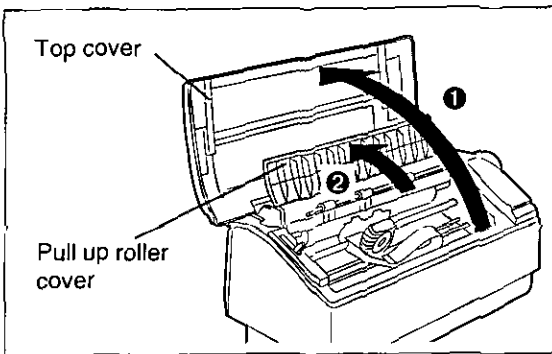

- 3**
- Install the ribbon cassette and push 4 arrows down until they click into place.

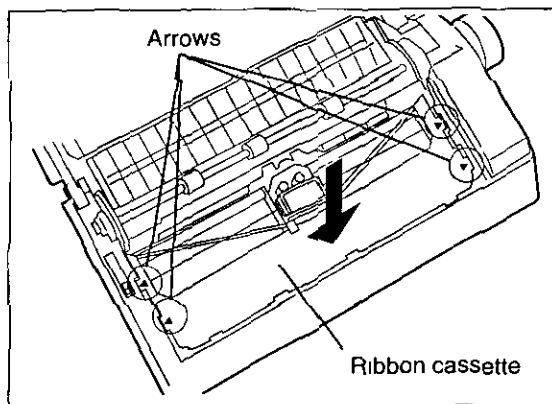

Note:

- Do not take off the blue ribbon guide from the ribbon

- 4**
- ① Lift the blue ribbon guide from the ribbon cassette.
 - ② Slide the blue ribbon guide between the printhead nose and the ribbon mask, and push it down.

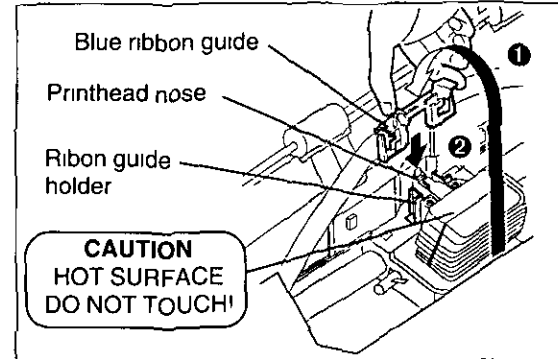

Note:

- If the ribbon does not insert easily between the printhead nose and the ribbon mask, rotate the knob on the ribbon cassette to reduce slack

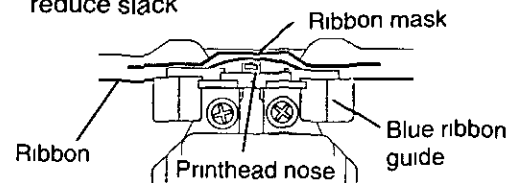

- 5**
- Make sure the ribbon is not twisted and rotate the knob to remove any slack.

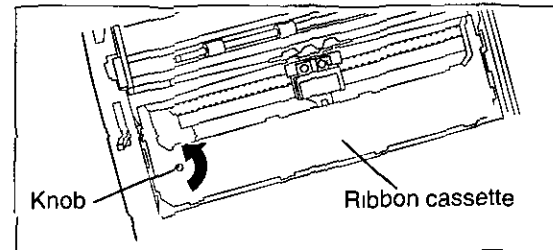

- 6**
- Close the pull up roller cover, then the top cover.

Note:

- If the top cover is replaced before the pull up roller cover, it may be damaged

- 7**
- Adjust the head gap lever for the thickness of paper you are using.



Position	Used for
1 or 2	Thinner sheets
3, 4, 5 or 6	Thick sheets or multi-part forms

Handling Paper

Installing Paper

- 1
 - 1 Remove the tape on the support bar.
 - 2 Grasp the tractor clamping levers and lift up to unlock tractors.
 - 3 Slide the tractors to the approximate width of the paper being used.

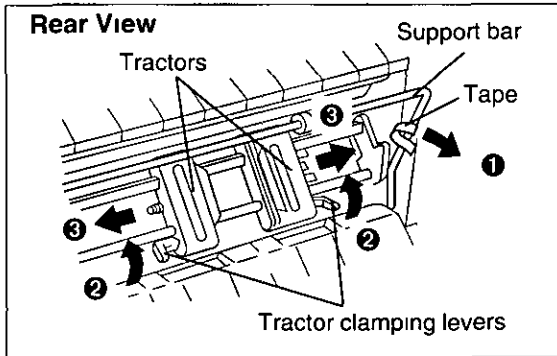

- 2 Open the tractor covers.

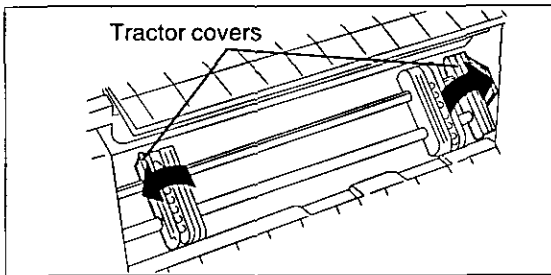

- 3
 - 1 Push sides of the support bar toward the center and lift the support bar.
 - 2 Pass the paper between the support bar and the printer.
 - 3 Place the paper onto the tractor sprockets, making sure paper is aligned straight.
 - 4 Close the tractor covers.

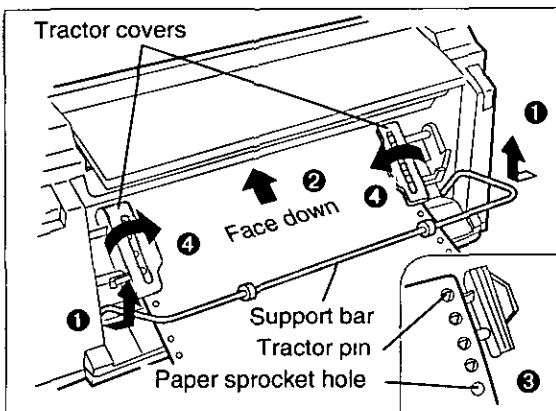

- 4
 - 1 Push the support bar down until it clicks into place.
 - 2 Adjust the tractors to remove any slack.
 - 3 Push the tractor clamping levers back to lock the tractors.

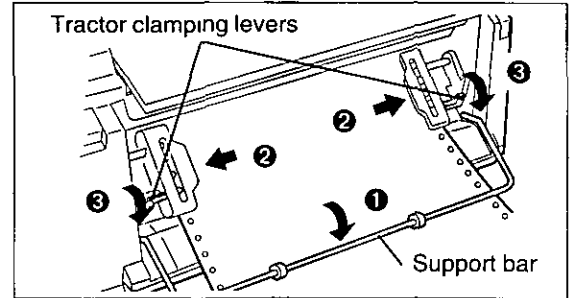

Note

- When reinstalling paper, first raise the support bar by pushing both sides toward center. Pushing the support bar too strongly may cause the support bar to release from the printer.

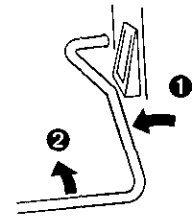

- 5 Raise the paper stand.

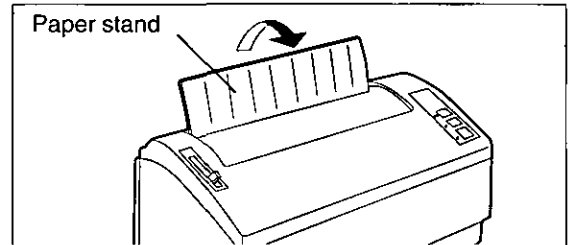

Note:

- To lower the paper stand, pull it upward, then lower into place.

- 6 Turn the power on.
- 7 Adjust the head gap lever for the thickness of paper you are using (P 8).
- 8 Press **LOAD** to load paper to the first print line.

Handling Paper/Printer Driver Selection

Tearing off Paper

The printer is equipped with an AUTO TEAR OFF feature that automatically advances the paper's perforation to the tear off position when printing is completed. This feature has already been set to ON at the factory and will advance the paper 0.8 seconds after printing is completed. You can turn this feature OFF or change the wait time (0.4~10 Seconds) through the AUTO TEAR OFF item in the INSTALL menu of the Control Panel Software program (P. 13~14). AUTO TEAR OFF can also be turned OFF and ON through the Control Panel in the Initial Setup mode (P. 18).

Note:

- When you tear off the paper, be sure to hold the printer to avoid totter and fall.

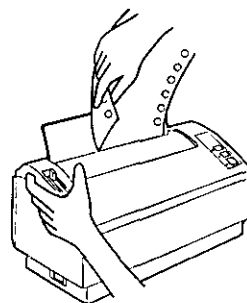

Self Test

The printer has a self test feature which allows you to test the printer. When activated, this feature will print 5 lines of each resident font. When complete, it will return to the draft font and continue approximately 10 minutes.

- 1** Install the ribbon cassette and paper, then turn the power off (P. 8~9).
- 2** While pressing **FONT**, turn the power on, then release.
- 3** Make sure all indicators are lit and press **LF/FF**.

A sample printout will begin, which serves as a self test.
- 4** Once you see that the printer is functioning properly, you may turn the power off during the self test, or you may run the entire test. (approximately 10 minutes)

Printer Driver Selection

This procedure is the final step before printing and is performed in your application software program. The steps will vary, depending on the software program. Consult your software package for proper procedures.

The Panasonic KX-P3200 will be your first choice. However, if the Panasonic KX-P3200 printer is not listed in your software, you must select an alternative from the following table.

Note: If using Microsoft Windows 3.1 or Windows 95, you will need to install a Windows printer driver. These drivers are located on the Setup Disk supplied with your printer. Proceed to Installing the Setup Disk on pages 11~12 for the installation procedure.

Printer Selections (in order of priority)

Panasonic KX-P3200
Panasonic KX-P1150
Panasonic KX-P2180
Epson FX-850
Panasonic KX-P1694
Panasonic KX-P3696
Panasonic KX-P1695
Epson FX Series
IBM Proprinter III *

* If selecting the IBM Proprinter III in your software, printer emulation must also be changed through the Control Panel Software program (P. 13~14) or using the Control Panel (P. 18).

Installing the Setup Disk

This Setup Disk can only be used in an IBM-PC or a compatible computer with a 3.5" floppy disk drive.

Before using the Setup Disk, it is recommended that you make a back-up copy and store the original in a safe place

The following steps will automatically create a directory called 3200 and copy Control Panel Software and Command Reference utility from the Setup Disk to your C Drive (You can change the directory and drive)



For DOS

Program	Function
Control Panel Software (CPS3200 EXE)	Allows you to view and change the printer settings on the computer screen
Command Reference utility (CMDREF EXE)	Allows you to access a detailed explanation of each software command on the computer screen

For installation, follow the steps below

- 1 Insert the Setup Disk into drive A or B
- 2 Type A: (or B.) and press **Enter** .
- 3 Type SETUP and press **Enter**
- 4 Follow the instructions on your computer screen

For Windows 3.1

Program	Function
Printer Driver	A printer driver is the part of the software that allows the software to communicate with the printer via the interface in use
Control Panel Software 	Allows you to view and change the printer settings on the computer screen
Command Reference utility 	Allows you to access a detailed explanation of each software command on the computer screen

For installation, follow the steps below

- 1 Start Windows 3 1
- 2 Insert the Setup Disk into drive A (or B).
- 3 Click **File** from the Program Manager window.
- 4 Click **Run...** .
- 5 Type A:\SETUP and then press **Enter** (or click **OK**)
- 6 Follow the instructions on your computer screen.

Installing the Setup Disk

For Windows 95

For Printer Driver



Program	Function
Printer Driver	A printer driver is the part of the software that allows the software to communicate with the printer via the interface in use

Windows 95 Supports Plug & Play functions. When you turn on your computer, Windows recognizes and sets up your hardware automatically.

For installation, follow the steps below

- 1 Connect interface cable to printer and computer, then power on printer
- 2 Start computer using Windows 95
- 3 When "New Hardware Found" dialog is displayed, click **OK**
- 4 Insert the Setup Disk into drive A (or B)
- 5 Click **OK**.
- 6 Select your Panasonic printer model
- 7 Click **Next**
- 8 Click **Next** to set up.
- 9 Select "Yes" and click **Next**
- 10 Click **Finish**.
- 11 Follow the instructions on your computer screen

For Utilities

Program	Function
Control Panel Software 	Allows you to view and change the printer settings on the computer screen
Command Reference utility 	Allows you to access a detailed explanation of each software command on the computer screen

For installation, follow the steps below

- 1 Start computer using Windows 95
- 2 Click **Start**, point to "Run."
- 3 Type A:\SETUP and then press **Enter** (or click **OK**).
- 4 Follow the instructions on your computer screen

Note

- If you cannot install the Printer Driver using Plug & Play, follow the steps below for installation

- 1 Insert the Setup Disk into drive A.
- 2 Click **Start**, point to "Settings" and "Printers"
- 3 Double click **Add Printer**, and click **Next**.
- 4 When the option "Local printer" or "Network printer" appears, select **Local printer** then **Next**
- 5 Click **Have Disk**, **OK**
- 6 Select your Panasonic printer model
- 7 Click **Next**
- 8 Click **Next** to set up.
- 9 Select "Yes" and click **Next**
- 10 Click **Finish**
- 11 Follow the instructions on your computer screen.

Using the Setup Disk

Control Panel Software Program

The printer allows you to select 30 initial setup items shown in the table below by using the Control Panel Software program.

The printer has been factory set to operate with most of the popular software packages. If no changes are required, you should be ready to print. In most cases there will be no need to change the initial setup items.

You can verify the current settings by pressing **(F5)** (see P. 14) after running the Control Panel Software program. You can also verify the factory and current settings by turning the power on while pressing **(READY)**.

Menu	Item	Menu	Item
PRINT STYLE	FONT	TEXT ENHANCEMENT	BOLD
	PITCH		DOUBLE HIGH
EMULATION	EMULATION		DOUBLE STRIKE
PAGE FORMAT	LINE/INCH		DOUBLE WIDE
	PAGE LENGTH		ITALICS
	TOP MARGIN		ZERO FONT
	BOTTOM MARGIN		CHARACTER SET
	LEFT MARGIN	CHARACTER SET	
RIGHT MARGIN	CODE PAGE		
CTR PRINthead	INSTALL	AUTO CR/IBM	
PRINT MODE		GRAPHIC DIRECTION	AUTO FEED XT CONTROL
		TEXT DIRECTION	AUTO LF
		N.L.Q. DIRECTION	AUTO TEAR OFF
			DOWNLOAD
			PAPER OUT DETECT
			SELECT 20CPI
			T.O.F. (Top of Form) SETTING
		T.O.F. SETTING	

Note:

- This program communicates between printer and computer. Before running this program under Windows 3.1 or Windows 95, be sure printing is completed.

To recall the programs, follow the steps below.

<For DOS>

1* At your C:\prompt, type CD 3200 and press **(Enter)**.

2 Type CPS3200 and press **(Enter)**.

<For Windows 3.1>

1 Select KX-P3200 Group.

2 Double click "Control Panel Software" icon.

<For Windows 95>

1 Click **(Start)**, point to "Programs", "KX-P3200" "Control Panel Software".

2 Click "Control Panel Software".

* If you changed the directory when installing utilities to DOS, select your changed directory and press **(Enter)**.

Using the Setup Disk

Note:

- If you want to run the Control Panel Software program using the Setup Disk, follow the steps below

1 Insert your Setup Disk into either drive A or B

<For DOS>

- 1 Type A (or B) and press **Enter**
- 2 Type CD DOS and press **Enter**
- 3 Type CPS3200 and press **Enter**

<For Windows 3 1>

- 1 Select **Run** from the File menu
- 2 Type A \DOS\CPS3200 (or B:\DOS\CPS3200)
- 3 Press **Enter** (or click **OK**)

<For Windows 95>

- 1 Click **Start**, point to **Run** and click it
- 2 Type A \DOS\CPS3200 (or B \DOS\CPS3200)
- 3 Press **Enter** (or click **OK**)

3 The first screen is an introduction to the operation of the Control Panel Software program. Please read it through and press any key to continue. (If your display is monochrome, press "M" key.)

4 The <Menu> window will be highlighted

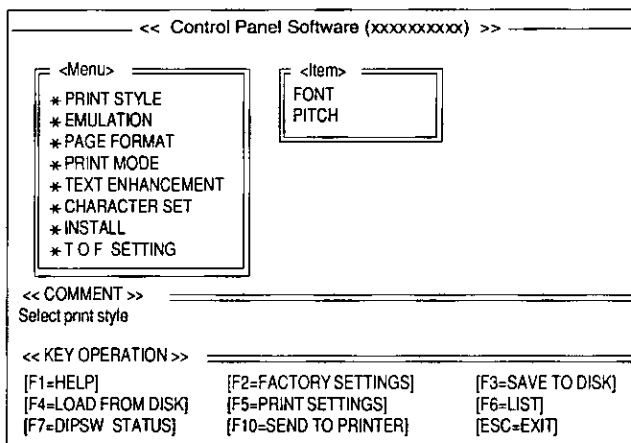

Note

You can proceed through the Control Panel Software program using a computer mouse or your arrow keys

Using the mouse

- Highlight the selection and click the left mouse button

Using the keyboard

- **↓** / **↑** to move within the current window
- **→** to advance to <Item> and <Setting> windows
- **Enter** to make selection in <Setting> window
- **←** to return to the previous window
- **TAB** / **SHIFT** + **TAB** to move the cursor in [SAVE TO DISK] and [LOAD FROM DISK] windows

F1	HELP	displays explanation of the functions
F2 *1	FACTORY SETTINGS	resets to the factory settings
F3	SAVE TO DISK	saves the setting as a file*2 to the Disk
F4	LOAD FROM DISK	loads your desired setting saved using F3 from the Disk
F5	PRINT SETTINGS	prints out the current settings
F6	LIST	displays the current setting list
F7	DIPSW STATUS	displays the current setting of the DIP switches
F10	SEND TO PRINTER	sends the settings to the printer
ESC	EXIT	exits the Control Panel Software program

*1 If you want to reset the printer settings to the factory settings when using the Control Panel Software program, press **F2** to recall the factory settings and then press **F10** to send the settings to the printer

2 "" "DAT" appears in the File Name position. Delete the * and enter a file name (up to 8 characters)

Command Reference Program

The Command Reference program allows you to access a detailed explanation of each software command on the screen. Each displayed explanation can be printed out if required.

Note

- You can print the **Character Set Tables**. On the SELECT COMMAND screen, press **C**. Then select your desired table and press **Enter**.
- If 7 bit is selected using the DIP switch for Data Length, you cannot print the command lists and character set tables.
- There is a list of proportional spacing tables after the software commands lists. If you want to see a proportional spacing table, select your desired table and press **Enter**.

To recall the programs, follow the steps below.

<For DOS>

- At your C:\prompt, type **CD 3200** and press **Enter**.
- Type **CMDREF** and press **Enter**.

<For Windows 3.1>

- Select **KX-P3200 Group**.
- Double click **"Command Reference"** icon.

<For Windows 95>

- Click **Start**, point to **"Programs"**, **"KX-P3200"** and **"Command Reference"**.
- Click **"Command Reference"**.

- * If you changed the directory when installing utilities to DOS, select your changed directory and press **Enter**.

Note.

- If you want to run the Command Reference program using the Setup Disk, follow the steps below.

- Insert your Setup Disk into either drive A or B.

<For DOS>

- Type **A** (or **B**) and press **Enter**.
- Type **CD DOS** and press **Enter**.
- Type **CMDREF** and press **Enter**.

<For Windows 3.1>

- Select **Run** from the File menu.
- Type **A:\DOS\CMDREF** (or **B:\DOS\CMDREF**).
- Click **OK** (or press **Enter**).

<For Windows 95>

- Click **Start**, point to **Run** and click it.
- Type **A:\DOS\CMDREF** (or **B:\DOS\CMDREF**).
- Click **OK** (or press **Enter**).

- The first screen is an introduction to the operation of the Command Reference program. Please read it through and press any key to continue. (If your display is monochrome, press "M" key.)

- Select the desired emulation and press **Enter** (or click **OK**).

The commands list will be displayed.

- Select the desired command and press **Enter** (or click **OK**).

The detailed explanation of the command will be displayed.

- Press **E** to exit to DOS.

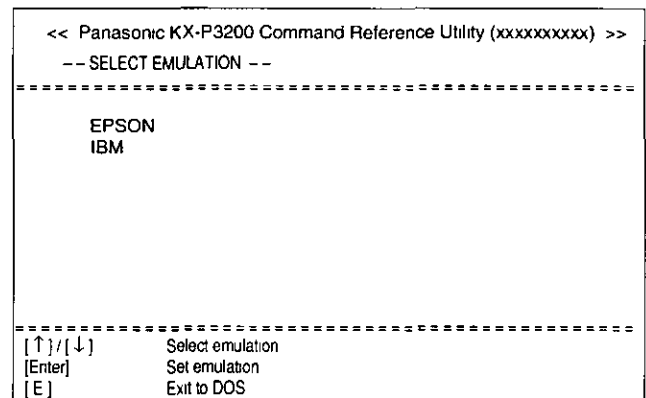

Using the Control Panel and DIP Switch

Selecting a Character Font

This printer contains resident fonts which are accessible through the Control Panel. You can select any one of the character fonts by pressing the FONT switch on the Control Panel.

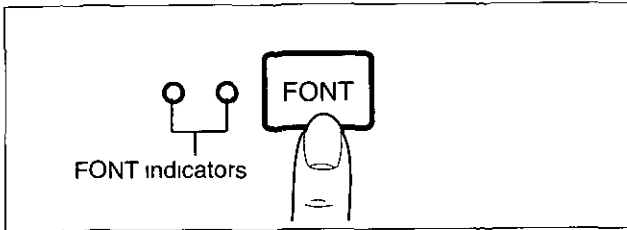

- Press and release **FONT**

The combination of FONT indicators indicates the current character font selected, as shown on the Control Panel.

Note:

- You must be in PROGRAM (both FONT indicators are off) to allow your software to control your font selection.

Line Feed/Form Feed **LF/FF**

You can adjust the paper position by using the front panel switches when the printer is not in the READY mode or when the printer is not printing in the READY mode.

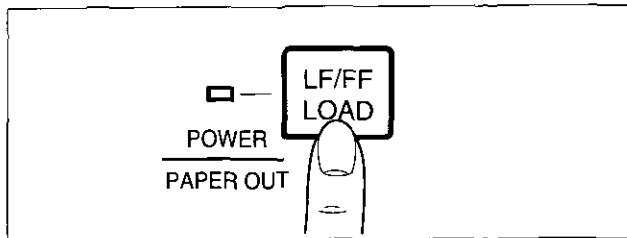

With paper installed, pressing **LF/FF** once advances the paper one line.

With paper installed, holding **LF/FF** moves the printhead to the center and advances the paper to the top of the next page.

Note:

- When pressing **LF/FF**, the amount of paper which is fed is determined by the current setting for lines per inch as specified by the Control Panel Software program or your application software.

Paper Load **LOAD**

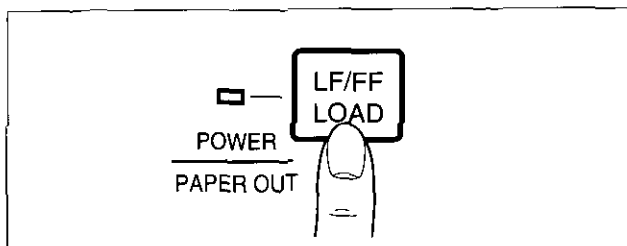

To load paper, first place the fanfold paper onto the tractors and then press **LOAD** to advance the paper to the first print line position.

Top of Form Function (TOF SET)

This printer has a Top of Form (TOF) function which stores the first print line position and loads the paper to the designated position automatically. The first print line position will be stored even after the power is turned off.

You can adjust the Top of Form position by using the Control Panel Software program (P 13), or using Micro Line Feed or Reverse Micro Line Feed from the Control Panel within 5" from the top of your paper.

Note:

- Do not rotate the platen knob, otherwise the printer will not be able to count the number of lines properly.
- All adjustments must be made on the first sheet. If you decide to change the setting and save it, remove the paper from the tractors, then reset and reload the paper.

1 If necessary, redefine the page length of the paper you are using through the Control Panel Software program (P 13~14), Control Panel (P 18) or your application software.

2 (Micro Line Feed)

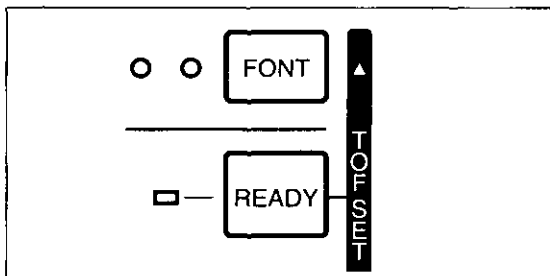

While pressing **READY**, press **FONT**.

This advances the paper one micro line (1/216")

(Reverse Micro Line Feed)

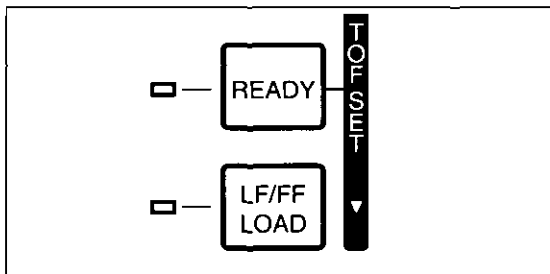

While pressing **READY**, press **LF/FF**.

This reverse the paper one micro line (1/216")
The printer cannot reverse the paper past the printable area (P 25 Printing Area)

3 At your desired position within 5" from the top of your paper, release the switches

The paper position will be stored automatically as the new Top of Form position

Paper Out Detector

Your printer has a paper out detector. When an out of paper condition occurs, printing stops, the READY indicator goes off (If the printer still has data, the READY indicator starts blinking), and the PAPER OUT indicator starts blinking. To continue printing to the end of the current page, follow the steps below.

1 Press **READY** repeatedly until the page is completed.

2 Insert the new paper and press **LOAD** (P 9).

Note:

- When PAPER OUT DETECT is set to ON, printing stops at 0.5" from the bottom of the paper.
- The paper out detector can be disabled through the Control Panel Software program (P 13)

Using the Control Panel and DIP Switch

Initial Setup Mode

The following features (items) can be set in the Initial Setup mode through the Control Panel, Emulation, Auto Line Feed, Auto Tear off, Graphic Direction, Page Length and Interface. Each time you press **FONT**, you will advance to the next item. Each time you press **READY**, the item's status will change. Select the desired setting according to the status of the indicators.

To enter the initial setup mode

While pressing **LF/FF**, turn the power on. If paper is installed, the current setting will be printed.

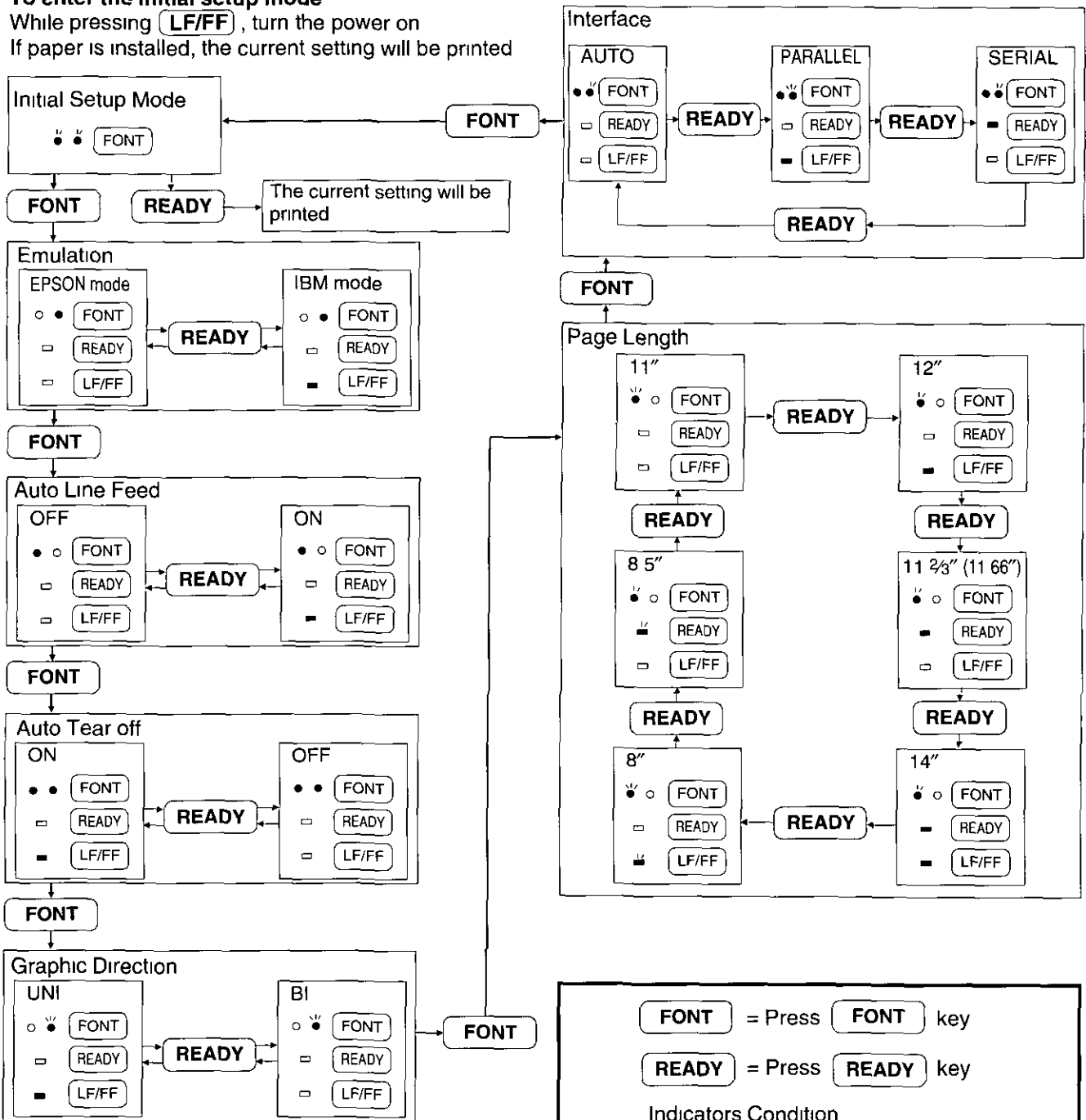

To exit the Initial Setup Mode

Press **LF/FF**. If paper is installed, the current setting will be printed.

Returning All Current Settings to the Factory Settings

This procedure will reset ALL settings to the original factory settings
This includes those settings made through the Control Panel Software program

- 1 While pressing **READY** and **FONT**, turn the power on, then release
- 2 Press **READY**.

Using the DIP Switch

The following serial interface items can be set by using the DIP switch, Baud Rate, Parity, Protocol, Data Length and Polarity. DIP switch is found on the bottom of the printer. Refer to the following charts to make any serial interface settings as necessary to match your computer system

- 1
 - 1 Turn the power off
 - 2 Unplug the power cord and interface cable from the printer
 - 3 Carefully turn the printer over as shown
- 2
 - 1 Slide the cover to the left.
 - 2 Move the DIP switches to the appropriate ON or OFF position.

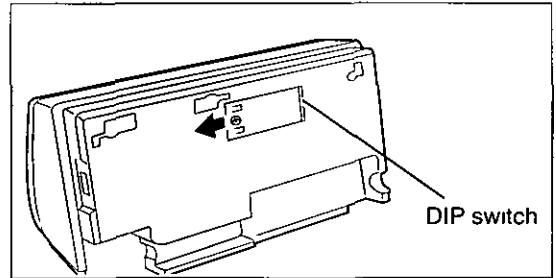
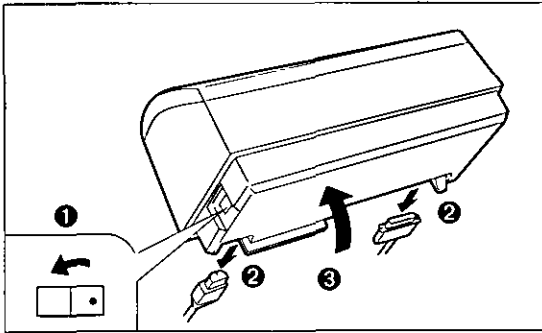

Note:

- Take care not to fall the printer and damage the covers when you set the DIP switches

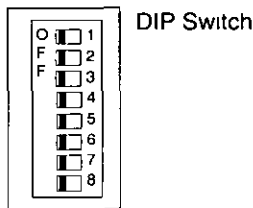

Chart 1

Switch	Function	ON	OFF
1	Baud Rate	Refer to Chart 2	
2			
3			
4	Parity	Refer to Chart 3	
5			
6	Protocol	XON/XOFF	DTR
7	Data Length	7 bit	8 bit
8	Polarity	SPACE	MARK

Chart 2

Baud Rate \ Switch	1	2	3
19200	ON	ON	ON
9600	OFF	OFF	OFF
4800	ON	OFF	OFF
2400	OFF	ON	OFF
1200	ON	ON	OFF
600	OFF	OFF	ON
300	ON	OFF	ON
150	OFF	ON	ON

Chart 3

Parity \ Switch	4	5
None	OFF	OFF
Ignore	ON	OFF
Odd	OFF	ON
Even	ON	ON

Factory Setting

Periodic Maintenance / Troubleshooting

Periodic Maintenance

The printer does not require routine maintenance. However, reasonable care of the printer will extend its life. The following periodic measures are recommended:

- Cleaning the unit is the most important action you can perform. The frequency of cleaning is dependent upon the environment.
 - Turn the power OFF and unplug the power cord.
 - Clean the case and covers with a soft cloth. Use any mild commercial cleaner on the cloth, do not spray directly on to the printer.
 - Raise the top cover and pull up roller cover. Vacuum or dust the inside area of the unit. Be very careful not to damage the printhead ribbon cable or the carriage drive belt.

Caution.

- The printhead may be hot, use caution when the cover is open.
- The platen should be cleaned with denatured alcohol only.
- The carriage guide bar can be lubricated with a very light oil. Contact your Authorized Panasonic Service Center for advice on lubrication.

Ribbon Cassette

Note

- If the ribbon begins to catch, snag, or tear from the printhead, your printer requires servicing.

Troubleshooting

Most problems associated with the printer can be traced to improper setup, installation, or cabling. The following table will assist you in identifying and correcting some of the more common problems. If you need additional help, contact the store from which the unit was purchased or the Panasonic technical support number found on the back cover of this manual.

Symptom	Possible Cause	Probable Solution
Ink smears	Head gap lever is not in proper position	Move the lever toward the position "6" until ink doesn't smear (P 8)
Printout is faint	Head gap lever is not in proper position	Adjust the lever to the proper position (P 8, 9)
Printhead moves but there is no printing	Ribbon is not installed correctly	Re-insert ribbon (P 8)
Paper out detector inoperative	PAPER OUT DETECT is OFF	Set PAPER OUT DETECT to ON (P 13)
Printer does not power up	No AC power	Check power cord (P 7)
Power is on but printer does not print	Printer is not READY	Press READY
	Interface cable is not properly connected	Secure connection (P 7)
	Out of paper	Install new paper (P 9)
	Printhead has become overheated	Allow the printhead some time to cool down. The printer will automatically resume printing.
	Wrong Interface setting is selected	Set interface setting to match the computer (P 18, 19)

(continued)

Symptom	Possible Cause	Probable Solution
Carriage stops moving, all indicators start blinking	Path of printhead is blocked	Turn the power off, clear the path. Turn the power back on to resume printing.
Unexpected characters appear in printing	EMULATION is set incorrectly	Check printer driver of your software package and set EMULATION accordingly (P 13, 18)
Fanfold paper is jamming	Paper is stuck on or under the platen	Remove jammed paper and reinstall paper correctly into tractors (P 9)
		Remove the platen, clear the debris and clean the platen (P 22)
32K Buffer Chip option (KX-P44) is installed but cannot download	DOWNLOAD is OFF	Set DOWNLOAD to ON (P 13)
Printout is double-spaced	AUTO LF is ON	Set AUTO LF to OFF (P 13, 18)
Keeps printing on the same line	Computer is not sending a LF command	Set AUTO LF to ON (P 13, 18)
Wrong character set prints	Wrong character set is selected	Set the character set as required (P 13)
Cannot print ASCII characters with code above 127	Data length is set incorrectly	Set data length as required (P 19)
When using serial interface, printer does not print or data loss occurs	Parallel interface is selected on your printer	Set interface setting to Auto or Serial (P 18)
	Baud rate, Parity, Protocol or Data length does not match with the computer	Set Baud rate, Parity, Protocol and Data length to match the computer (P 19)
Paper is not advanced automatically when printing is completed	Auto tear off, Page length, Top margin and Bottom margin are set incorrectly	Set Auto tear off to ON and set Page length, Top margin and Bottom margin to meet your software package (P 13)

Options and Supplies

Description	Model Number
Ribbon Cassette	KX-P180
32 K Buffer Chip	KX-P44

These items are subject to change without notice

Troubleshooting

Platen Removal

This procedure is to allow easy access for removing jammed labels or paper

Caution:

- If the printer has been operating, the printhead may be hot. Use caution or allow unit to cool before attempting removal of the platen

1 Remove the platen knob by pulling straight out

2 Raise the top cover.

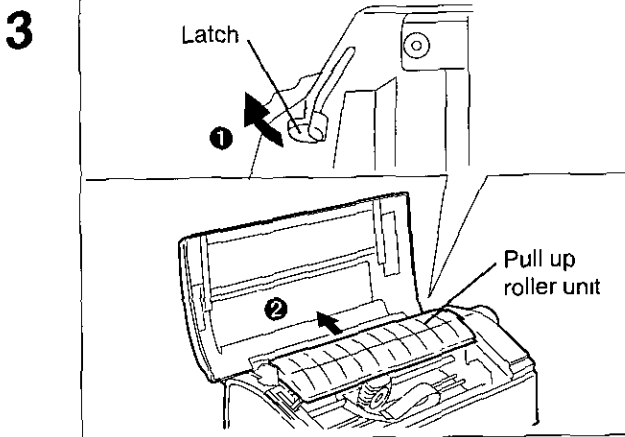

1 Release the latches on the pull up roller unit.

2 Remove the pull up roller unit by pulling straight up

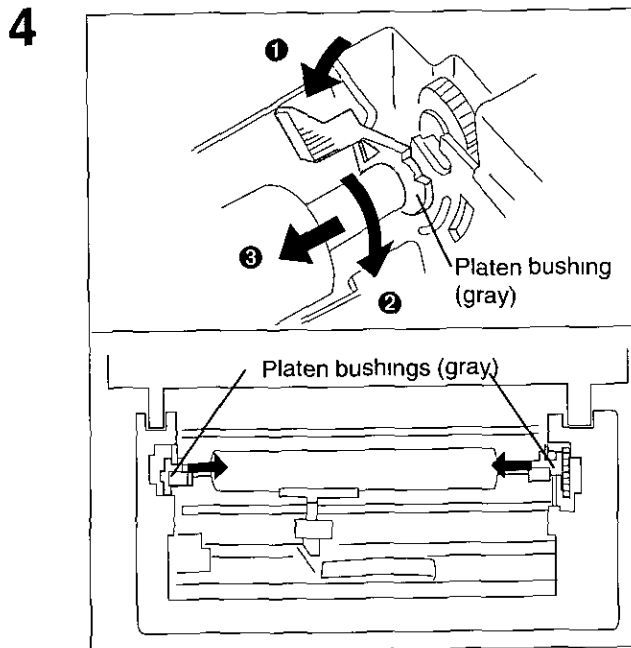

To release the platen bushings.

A **1** Push the right platen bushing (gray) in and
2 Rotate the platen bushing towards the front of the printer.

3 Slide the platen bushing inward along the platen shaft

B **1** Push the left platen bushing (gray) in and

2 Rotate the platen bushing towards the front of the printer

3 Slide the platen bushing inward along the platen shaft

5 Remove the platen by lifting from the left side.

Platen Installation

1 Move the head gap lever to position "6".

2

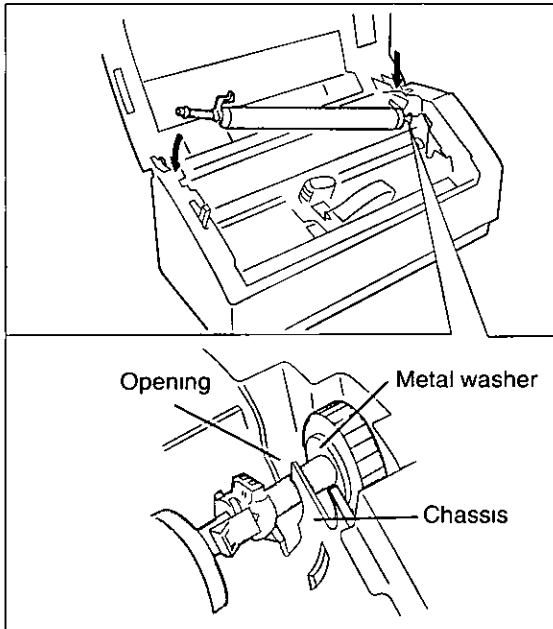

Lower the platen into the openings of the chassis (right side first).

Note:

- Make sure the metal washer on the right side of the platen is on the outside of the chassis

3

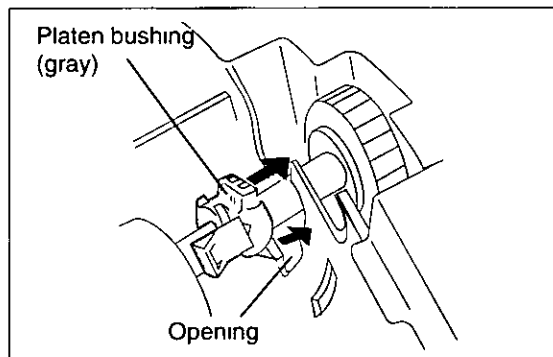

A Align the right platen bushing with the opening in the chassis and slide the bushing into the opening

B Align the left platen bushing with the opening in the chassis and slide the bushing into the opening.

4 Rotate the platen bushings towards the rear of the printer until they latch into place

5 Replace the pull up roller unit

Note:

- Take care not to damage the cover when replacing the pull up roller unit

6 Replace the top cover

7 Reinstall the platen knob.

Printer Specifications

Power requirements	Refer to the nameplate located on the rear of the printer			
Frequency				
Current				
Interface	Centronics parallel RS-232C/Serial interface			
Print fonts	3 Draft (Pica, Elite, Micron) 4 Near Letter Quality (Roman, Sans Serif, Courier, Bold PS) 2 High Speed Draft (Pica, Elite)			
Software emulation	Epson FX-850 IBM Proprinter III			
Buffer	12 K (standard), additional 32 K (optional KX-P44)			
Character sets	EPSON mode ONE Italic and 17 characters set tables 15 International characters and LEGAL Set IBM mode 17 character set tables			
Dot configuration	1/84 inch (0.3 mm) dot diameter			
		Draft	NLQ	HSD
	Matrix (Hor × Ver)	9 × 9	18 × 18	8 × 9
	Dot pitch (Hor)	1/120" (0.21 mm)	1/240" (0.11 mm)	1/90" (0.28 mm)
	(Ver)	1/72" (0.35 mm)	1/144" (0.18 mm)	1/72" (0.35 mm)
Maximum number of characters per line (cpl)	Font	Print line size 8"		
	Pica [10 cpl (character per inch)]	80 cpl		
	Elite (12 cpl)	96 cpl		
	Micron (15 cpl)	120 cpl		
	Compressed (17 cpl)	137 cpl		
	Elite compressed (20 cpl)	160 cpl		
Printing speed [characters per second (cps)]		Micron	Elite	Pica
	Draft	330 cps	264 cps	220 cps
	NLQ	44 cps	53 cps	44 cps
	HSD		317 cps	264 cps
Printing direction	Uni-directional / Bi-directional (user selectable)			
Line feed time	Approx 90 msec [with 1/6 inch (4.2 mm) line feeding]			
Paper feed	Push tractor feed (with fanfold paper)			
Operating environment	Temperature 10°C–35°C {50°F–95°F} Humidity 20–80% RH (Please allow the printer to stabilize at room temperature within the operating temperature range before operation)			
Power consumption	Max — 90 W Stand by — 10 W Self Test — 60 W			
Storage environment	Temperature –20°C–60°C {–4°F–140°F} Humidity 10–90% RH			
Head service life	Approx 200 million strokes in DRAFT mode			
Ribbon	Endless fabric ribbon Black ribbon cassette KX-P180 Life expectancy (in DRAFT mode/rolling ASCII) Approx 6 million characters			
Detectors	Paper out detector Overheat detector Overload detector			
Dimensions	427 (W) × 215 (D) × 197 (H) mm {16.8" × 8.5" × 7.8"}			
Mass (Weight)	Approx 4.9 kg {10.8 lbs }			
CPU	TOSHIBA CORPORATION TMP90C845F 16 MHz			

Paper Specifications

Paper which may be used with this unit must be within the specifications provided below

Width 4~10 inches (102~254 mm)

Quality and number of sheets:

Type of paper	Sheets	Weight	
		lbs	g/m ²
Fine-quality paper	1	16~24	60~90
Non-carbon	2~5	11~14 (17*)	41~53 (64*)
Multi-layered with carbon	2	11~14 (17*)	41~53 (64*)

(* only for the last sheet)

Note:

- To insure optimum print quality, 16~22 lbs (60~82.5 g/m²) is recommended for graphic printing
- In multi-layered paper with carbon, the carbon is equivalent to a sheet of paper
- "Weight in pounds" represents the weight of 500 [17 × 22 inches (432 × 559 mm)] sheets
- The printer will handle multipart forms up to 0.014 inch (0.36 mm) thick. Up to 5 copies of 14 lb chemical release paper can be used

Printing Area

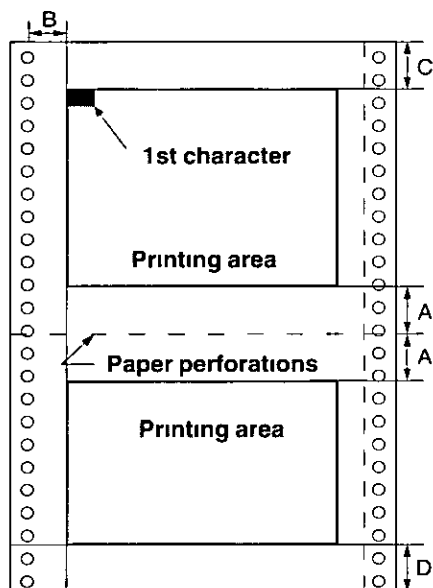

A	1" (25.4 mm)
B	0.7" (17.8 mm)
C*	0.33" (8.38 mm)
D	1" (25.4 mm)

* You can set the first print line at 0, however, 0.33" or more is recommended to insure optimum print quality

- A:** The area near the paper perforations where the print quality may not be optimum
- B:** The minimum distance between the sprockets and first printable character (When the left tractor is set on the left end and the margin is set to 0)
- C:** The area from the top edge of the paper to the top of the first printed character where the print quality may not be optimum
- D:** The area from the bottom edge of the paper where the print quality may not be optimum

Interfacing

This information should be provided to the company from which you are purchasing the Printer Cable to ensure the proper wiring of the cable

Parallel Interfacing

The parallel interface is a bidirectional parallel interface and it conforms to IEEE standard 1284-B
A method of transferring data from a computer to a printer through a parallel interface based on the Centronics Standard

Specifications:

- data transfer speed 1000 cps minimum
- synchronization external STROBE pulse
- logic levels TTL (Transistor-Transistor-Logic) levels
- handshaking BUSY and ACK signals
- connector type 57-30360 (AMPHENOL) or equivalent
- cable use a shielded cable 6'5" {1.95 m} or less in length

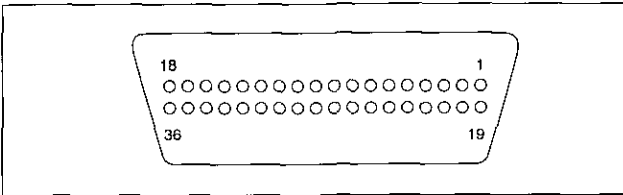

Parallel Interface Connector (printer side)

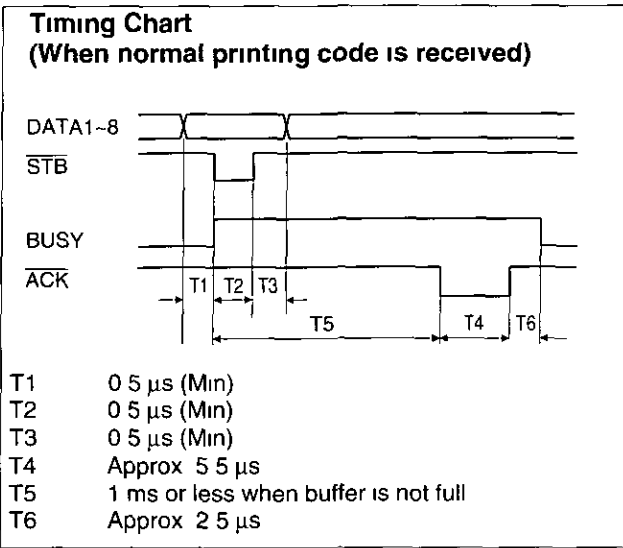

Timing Diagram

Signal pin	Return side pin	Signal	Direction
1	19	STB	Input
2	20	DATA 1	
3	21	DATA 2	
4	22	DATA 3	
5	23	DATA 4	
6	24	DATA 5	
7	25	DATA 6	
8	26	DATA 7	
9	27	DATA 8	Output
10	28	ACK	
11	29	BUSY	
12		PO	
13		SLCT	Input
14		AUTO FEED XT	
15			
16		SG	
17		FG	
18		+5 V	Output
31	30	PRIME	Input
32		ERROR	Output
33			
34			
35			
36		SLCT IN	Input

Pin Configuration

Serial Interfacing

- cable use a shielded cable 6'5" {1.95 m} or less in length

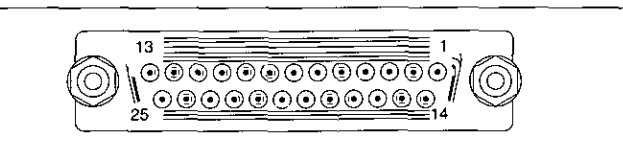

Serial Interface Connector (printer side)

Signal pin	Signal	Direction
1	FG	
2	TXD	OUTPUT
3	RXD	INPUT
7	SG	
20	DTR	OUTPUT

Pin Configuration

Index

A

- Automatic Carriage Return (AUTO CR) 13
- Automatic Line Feed (AUTO LF) 13, 18

B

- Buffer 21, 24

C

- Cable 7
- Centering (CTR PRINTHEAD) 13
- Character sets 13, 15
- Code page 13

D

- Data length 19
- Detectors 17, 24
- Dot configuration 24

E

- Emulation 13, 18

F

- Factory setting 14, 19
- Fanfold paper 9, 25
- Font 24
- Form feed 16
- Front panel switches 6, 16, 17

G

- Graphic direction 13, 18

H

- Head service life 24

I

- Interfacing 7, 18, 26
- Italics 13

L

- Line feed 16

M

- Maintenance 20
- Margin 13
- Micro line feed 17

N

- Near Letter Quality (NLQ) 24
- N.L.Q direction 13

O

- Operating environment 5
- Options 21

P

- Page format 13
- Page length 13
- Paper installation 9
- Paper specifications 25
- Paper thickness 25
- Parallel interface 7, 26
- Parts of the printer 6
- Power requirement 24
- Power switch 6, 8
- Print direction 13, 24
- Print speed 24
- Print style 13
- Printer driver 10, 11, 12
- Printing area 25
- Proportional Spacing (PS) 15

R

- Reverse micro line feed 17
- Ribbon cassette 2, 8, 20

S

- Serial interface 7, 26
- Setup Disk 2, 13
 - Command Reference program 15
 - Control Panel Software program 13
 - Printer driver 10, 11, 12
- Specifications 24, 25

T

- Tear Off 10, 13, 18
- Text direction 13
- Top of Form (TOF) set 13, 17
- Troubleshooting 20

U

- Unpacking 2

W

- Windows printer driver 11, 12

Z

- Zero font 13

FOR USERS IN THE UNITED STATES ONLY

This equipment has been tested and found to comply with the limits for a Class B digital device, pursuant to Part 15 of the FCC Rules. These limits are designed to provide reasonable protection against harmful interference in a residential installation.

This equipment generates, uses and can radiate radio frequency energy and, if not installed and used in accordance with the instructions, may cause harmful interference to radio communications.

However, there is no guarantee that interference will not occur in a particular installation. If this equipment does cause harmful interference to radio or television reception, which can be determined by turning the equipment off and on, the user is encouraged to try to correct the interference by one or more of the following measures:

- Reorient or relocate the receiving antenna.
- Increase the separation between the equipment and receiver.
- Connect the equipment into an outlet on a circuit different from that to which the receiver is connected.
- Consult the dealer or an experienced radio/TV technician for help.

The user may find the booklet "Something About Interference" available from FCC local regional offices helpful.

FCC Warning To assure continued FCC emission limit compliance, the user must use the recommended shielded interfacing cable when connecting to a host computer. Also, any unauthorized changes or modifications to this equipment would void the user's authority to operate this device.

Technical Support Calls

If you have read this manual and tried the troubleshooting procedures and you are still having difficulty, please contact the store from which the unit was purchased.

You may also call the technical support telephone number which is operational during east coast business hours (9:00 AM to 7:00 PM).

For technical support, to order options and supplies, or for the nearest authorized service center please call 1-800-222-0584.

**Panasonic Communications & Systems Company,
Computer Products Division
Division of Matsushita Electric Corporation of America
Two Panasonic Way, Secaucus, New Jersey 07094**

**Panasonic Sales Company
Division of Matsushita Electric of Puerto Rico, Inc
San Gabriel Industrial Park, 65th Infantry Avenue KM 9.5
Carolina, Puerto Rico 00630**

**Matsushita Electric of Canada Limited
5770 Ambler Drive, Mississauga, Ontario, L4W 2T3**

**Matsushita Electric Industrial Co., Ltd.
Central P.O. Box 288, Osaka 530-91, Japan**
